

ThermAir Burners

Model TA200 *version 1.00*

Main Specifications - TA200

PARAMETER		SPECIFICATIONS	
		English	Metric
Maximum input (To maintain 15% excess air with the standard air orifice and standard combustion air blower.)	60 Hz packaged blower	Capacity @ Chamber Pressure	
		BTU/hr @ "w.c.	kW @ mbar
		2,071,000 @ -1.0	607 @ -2,5
		2,000,000 @ 0.0	587 @ 0,0
		1,871,000 @ 1.0	549 @ 2,5
Minimum input	Natural Gas, Propane or Butane	BTU/hr	kW
		66,000	19,4
Main gas inlet pressure • fuel pressure at gas inlet (Tap "B")	Natural Gas	9.4 "w.c.	23 mbar
	Propane	9.8 "w.c.	24 mbar
	Butane	9.8 "w.c.	24 mbar
High fire flame length • measured from the burner flange.	Natural gas	50 in	1270 mm
	Butane or Propane	48 in	1220 mm
Maximum chamber temperature	Alloy Tube	°F	°C
		1500	815
Flame detection	UV scanner only		
Fuel	Natural Gas, Propane or Butane. <i>For any other mixed gas, contact Eclipse Combustion for orifice sizing</i>		

- All information is based on laboratory testing in neutral (0.0"w.c.) chamber with standard combustor design. Different chamber conditions and/or combustor design will affect the data.
- Maximum inputs are given for the standard combustion air blower without an air filter.
- All inputs based upon gross calorific values and standard conditions: 1 atmosphere, 70° F (21°C).
- Blower motor service factors greater than 1.0 may be required when firing into negative chamber pressure applications. For specific application questions, contact your Eclipse Combustion representative.
- Eclipse reserves the right to change the construction and/or configuration of our products at any time without being obliged to adjust earlier supplies accordingly.



Eclipse Combustion

ISO 9001 Registered

Performance Graphs ThermAir TA200

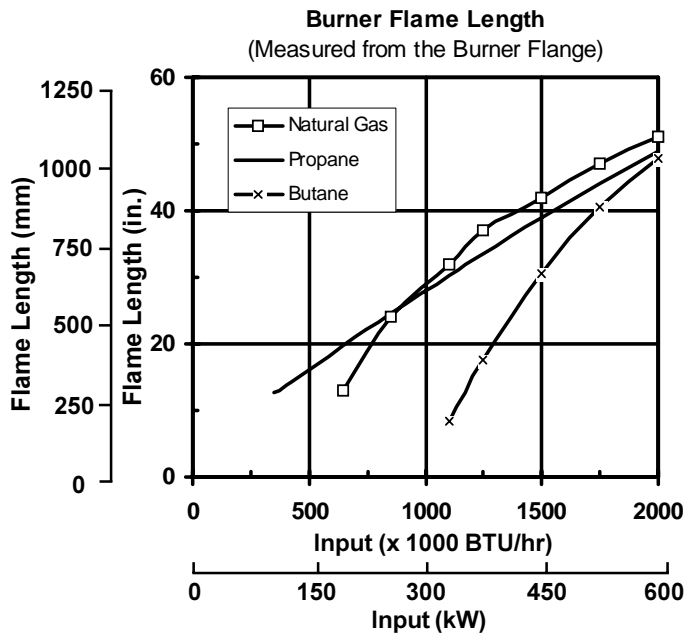
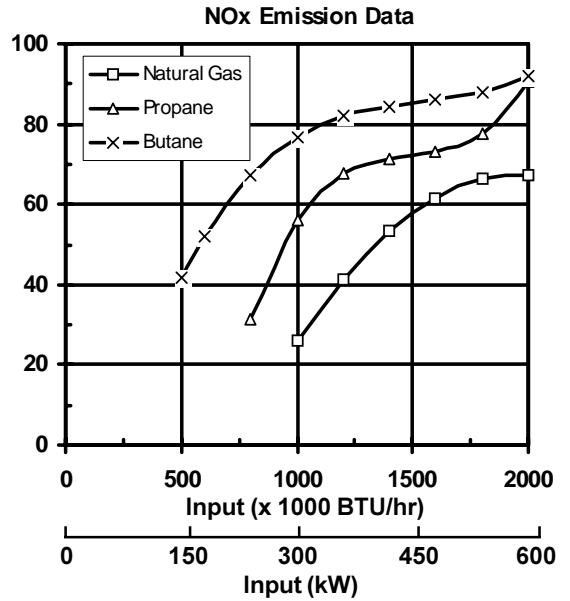
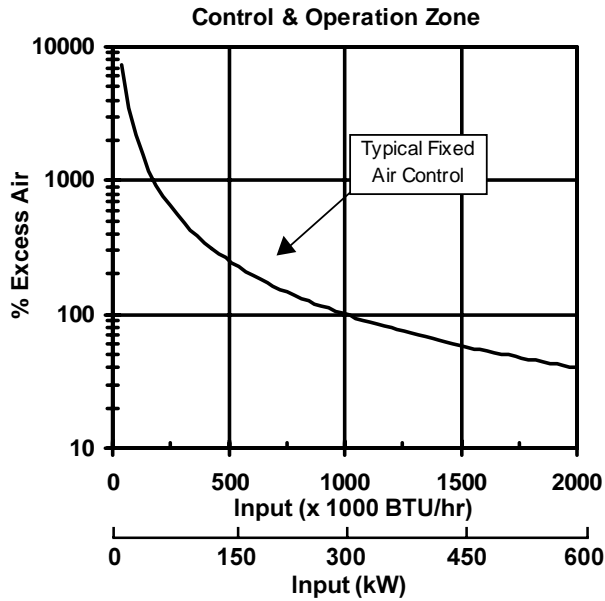

Notes on emission data

NOx emission data is given for:

- Ambient combustion air ~70° F (20° C)
- Minimal process air velocity
- ppm volume dry at 3% O₂
- Neutral chamber pressure

Emissions are influenced by:

- Chamber conditions
- Fuel type
- Firing rate
- Combustion air temperature

CO emission is largely influenced by chamber conditions. Contact your local Eclipse Combustion representative for an estimate of CO emission on your application.

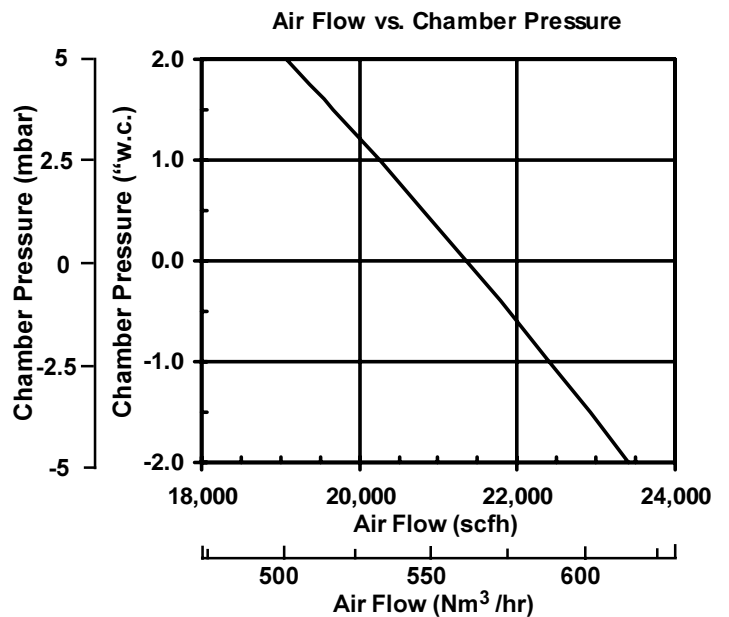
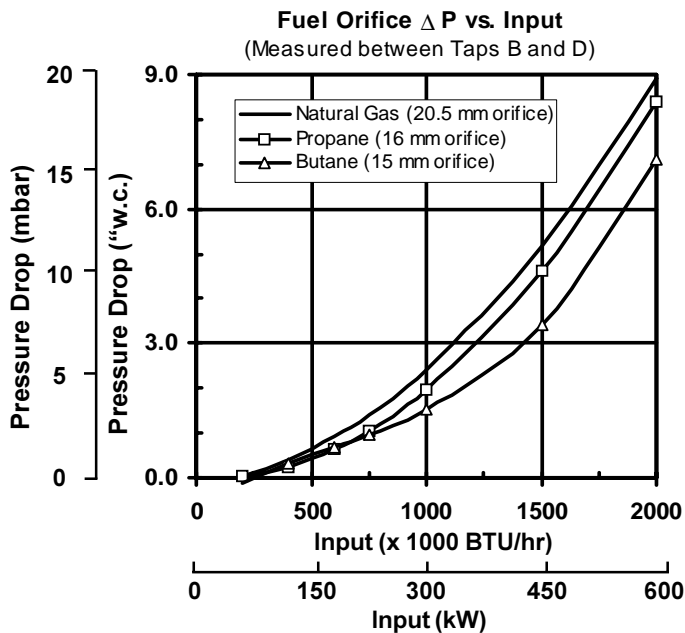

Dimensions-TA200

mm (in)

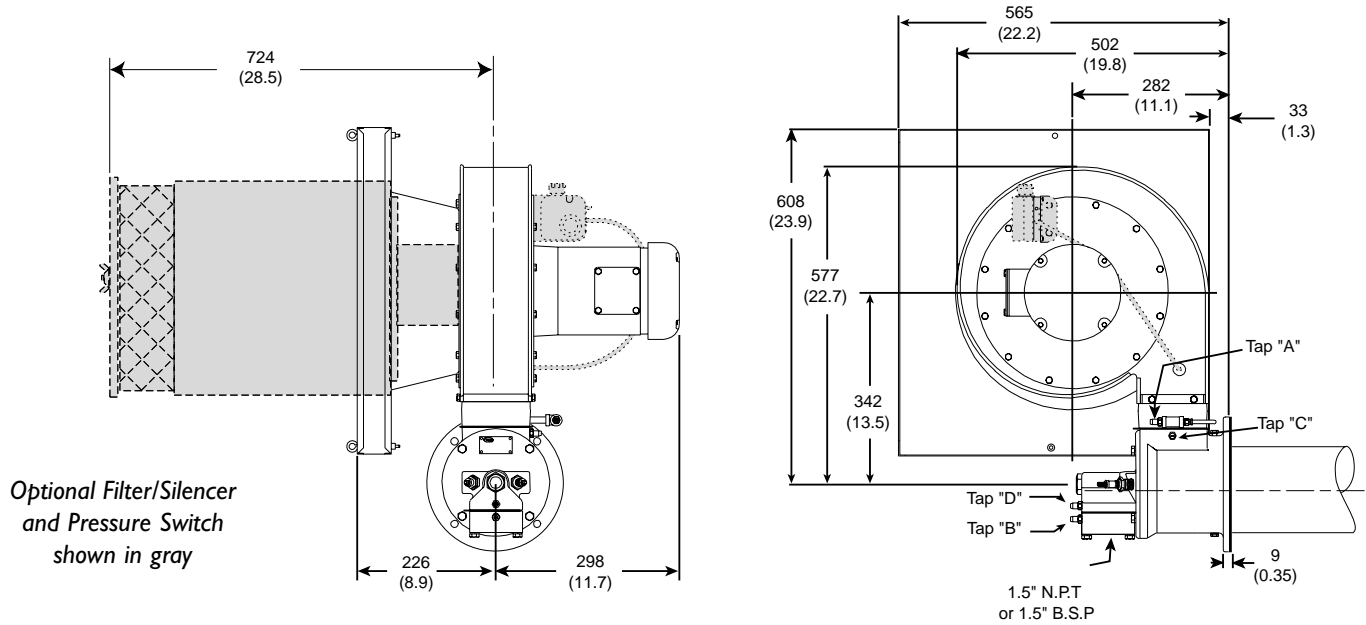

Port Connections		
Sparkplug	14mm	
Flamerod or Scanner	0.5" NPT	
Peepsight	0.75" NPT	
Weights		
Burner, w/ blower	99	45
Burner, less blower	46	21
Filter/Silencer	41	19

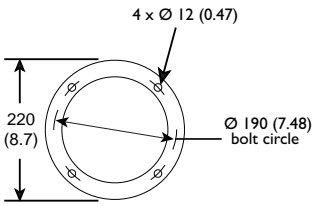

Mounting Pattern

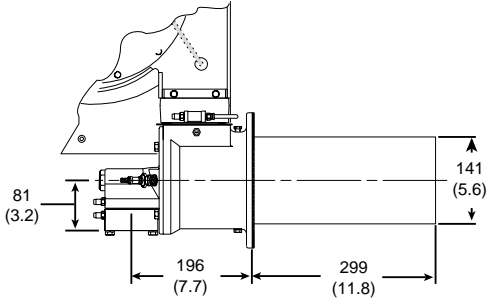

310 Stainless Steel Alloy Tube

Piping

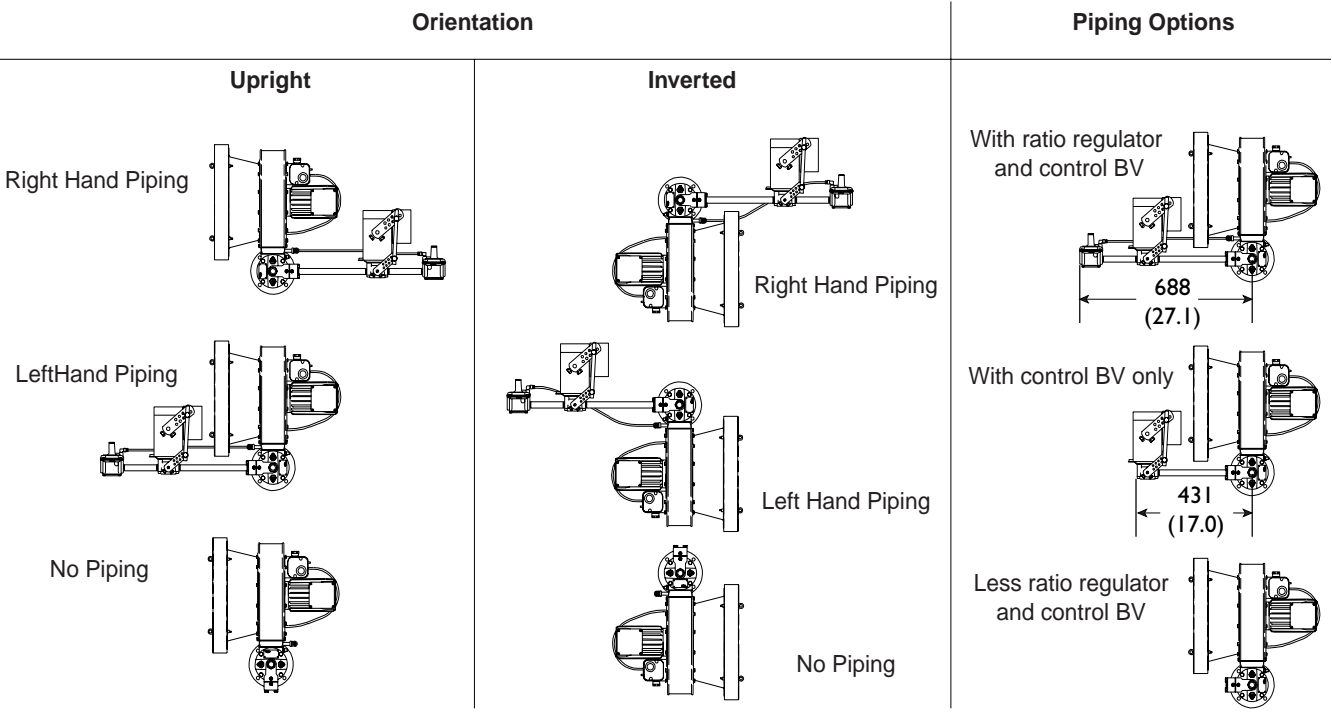



Offered By:

Power Equipment Company
2011 Williamsburg Road
Richmond, Virginia 23231
Phone (804) 236-3800
Fax (804) 236-3882

www.peconet.com